

ASPEN RIDGE-II

- SECTION THRU DOOR -

SHEET _____ OF _____ DATE _____

JOB _____

CONTRACTOR _____

ARCHITECT _____

DISTRIBUTOR _____

REV. #: 0 DWG. NO. 4121-1011

SCALE - NONE DRAWN BY: MWH

Controlled

- GLAZING DETAIL -

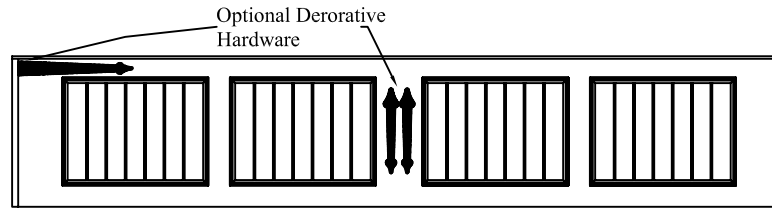
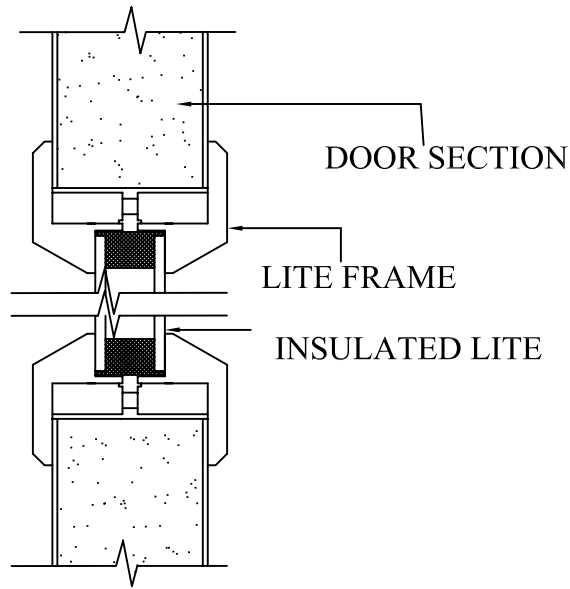

- EXTERIOR SECTION ELEVATION -

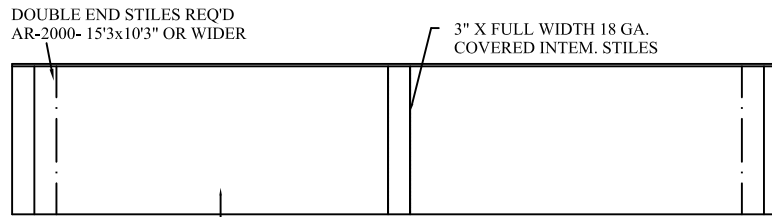

- INTERIOR SECTION ELEVATION -

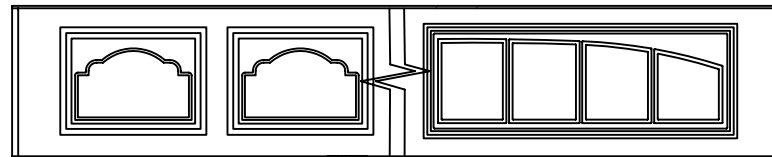

- 17" X 12" & 44"X15" WINDOW INSERTS W/OPTIONAL CATHEDRAL & WYNDBRIDGE COVERS-

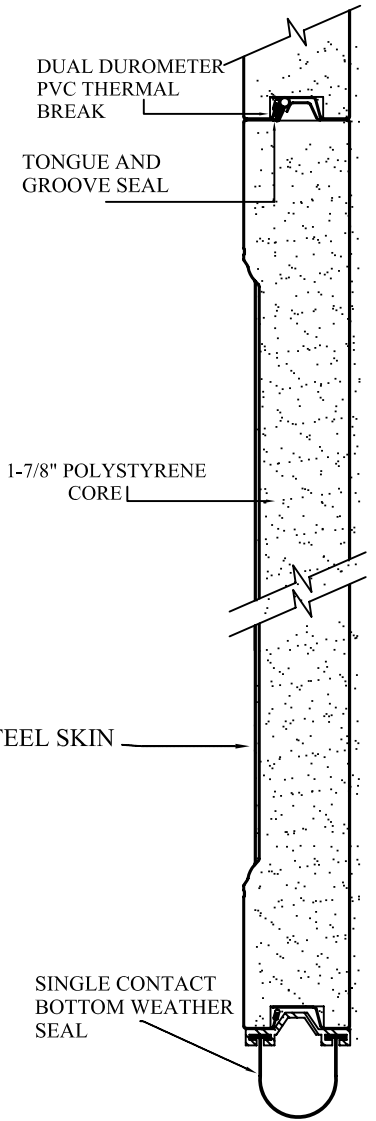

DOOR	Qty.	WIDTH	HEIGHT	COLOR (WHT, BRN, ALM, SAN, ETT) (SEP, GRN, BGE, K. WHT)	END STILE TYPE	# of SECT.	# of PANELS	# of WINDOWS	WINDOW SIZE	WINDOW PLACEMENT	LOCK (key or slide lock optional)
A											
B											
C											

DWG is not all inclusive.
Designed to be accompanied by Arch. Specs and Track Dwg.