

NOTES:

- * DOORS & HARDWARE WILL BE DESIGNED & MANUFACTURED & INSTALLED ACCORDING TO STANDARDS ESTABLISHED BY THE DOOR ACCESS SYSTEMS MANUFACTURING ASSOCIATION (DASMA).
- * IN DOOR SECTIONS WHERE WINDOW LITES ARE INSTALLED, STRUTS MAY BE RELOCATED OVER HINGE LEAFS TO AVOID OBSTRUCTION.
- * AN INSIDE SLIDE LOCK SHOULD BE MOUNTED ON END STILE APPROXIMATELY 31" FROM BOTTOM OF DOOR ON THE INTERIOR LEFT.

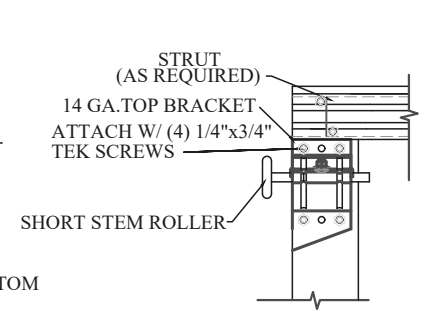

TOP BRACKET DETAIL
DETAIL 1/S1.1

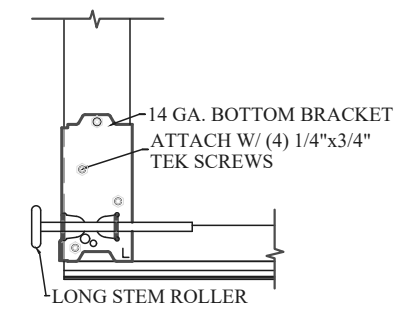

BOTTOM BRACKET DETAIL
DETAIL 2/S1.1

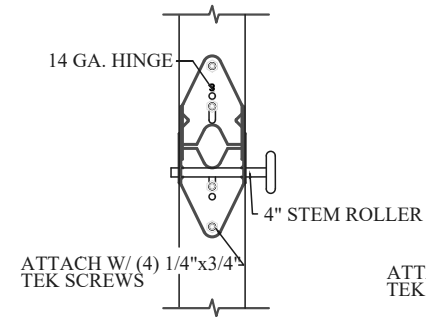

END HINGE DETAIL
DETAIL 3/S1.1

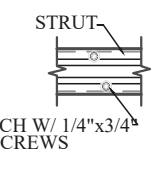

STRUT DETAIL
DETAIL 4/S1.1

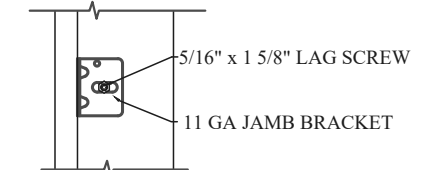

JAMB BRACKET DETAIL
DETAIL 5/S1.1

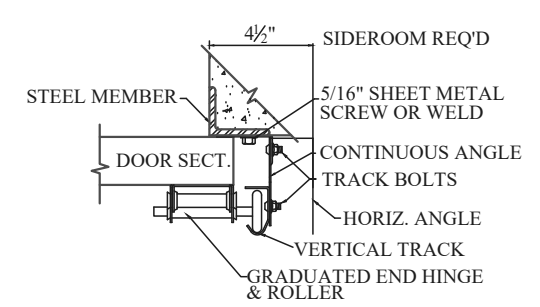

STEEL JAMB DETAIL (TYPICAL)
SECTION 'B-B'

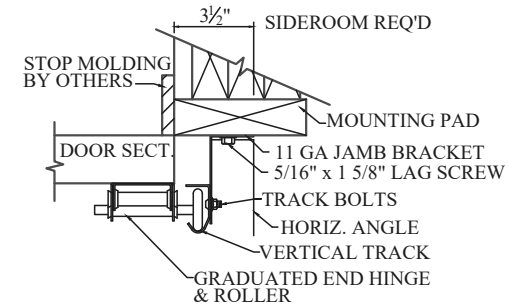

WOOD JAMB DETAIL (TYPICAL)
SECTION 'B-B'

MODELS: All 1 3/8" Models, All 2" Models (except TF-II)
DESIGN PRESSURE +17.5/-19.6 PSF

TESTED PER THE APPLICABLE REQUIREMENTS OF:
Pressures conform to ASCE-7-10 with the following parameters:
115 mph ultimate design wind speed
Exposure C
ASTM: E 330 ANSI/DASMA 108-2002

NOTE: THE DESIGN OF SUPPORTING STRUCTURAL ELEMENTS SHALL BE THE RESPONSIBILITY OF THE PROFESSIONAL OF RECORD FOR THE BUILDING OR STRUCTURE IN ACCORDANCE WITH CURRENT BUILDING CODES

		ENGINEERING DRAWING	
		10'2" MAX. WIDTH, WIND LOAD RATED DOOR	
MODEL #	AR-138, ARL-138, LP-138, TF-138, TR-138, AR-II, ARL-II, LP-II, TR-II	REV. NO.	0
SCALE	N/A	SHEET	OF
		DATE	